



BY HOMY

SUBMITTAL

AIR TO WATER

HEAT PUMP

EVI DC INVERTER



Maximum Water Temperature: **149°F** (65°C)



APPLICATIONS INCLUDE:

- Space heating
- Space cooling
- Domestic hot water production
- Radiant floor heating
- Fan coil systems
- Low temperature hydronic systems

The GreenTech ASTRA R454B EVI DC Inverter Air Source Heat Pump is a high-efficiency air-to-water system designed for residential and light commercial applications. The unit utilizes environmentally friendly R454B refrigerant with low Global Warming Potential (GWP 467) and advanced DC inverter technology with Enhanced Vapor Injection (EVI) for stable operation in low ambient conditions.

PROJECT NAME: _____

PROJECT LOCATION: _____

SUBMITTED BY: _____

DATE: _____



GTCHRW12ZA
21,000~61,000 BTU/h



GTCHRW18ZA
22,000~76,000 BTU/h

LAYOUT OF COMPONENTS

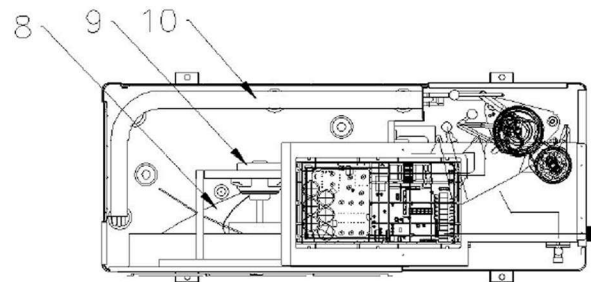
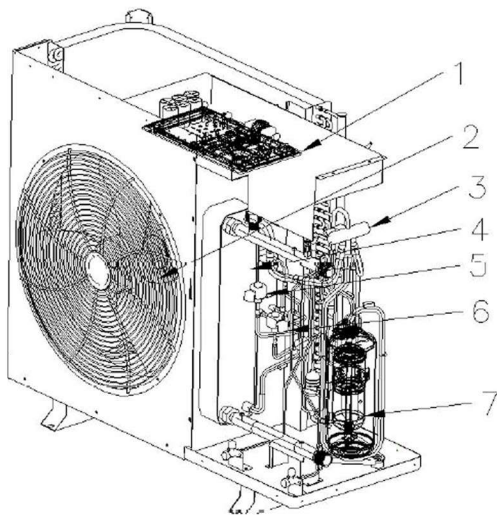

GTCHRW12ZA-PBEN11

- 1. Electric Control Box
- 2. Fan Blade
- 3. Four-Way Valve
- 4. Plate Heat Exchanger
- 5. Main Electronic Expansion Valve
- 6. Secondary Electronic Expansion Valve
- 7. EVI DC Inverter Compressor
- 8. Fan Guard
- 9. Fan Motor
- 10. Hydrophilic Aluminum Fin Heat Exchanger

LAYOUT OF COMPONENTS

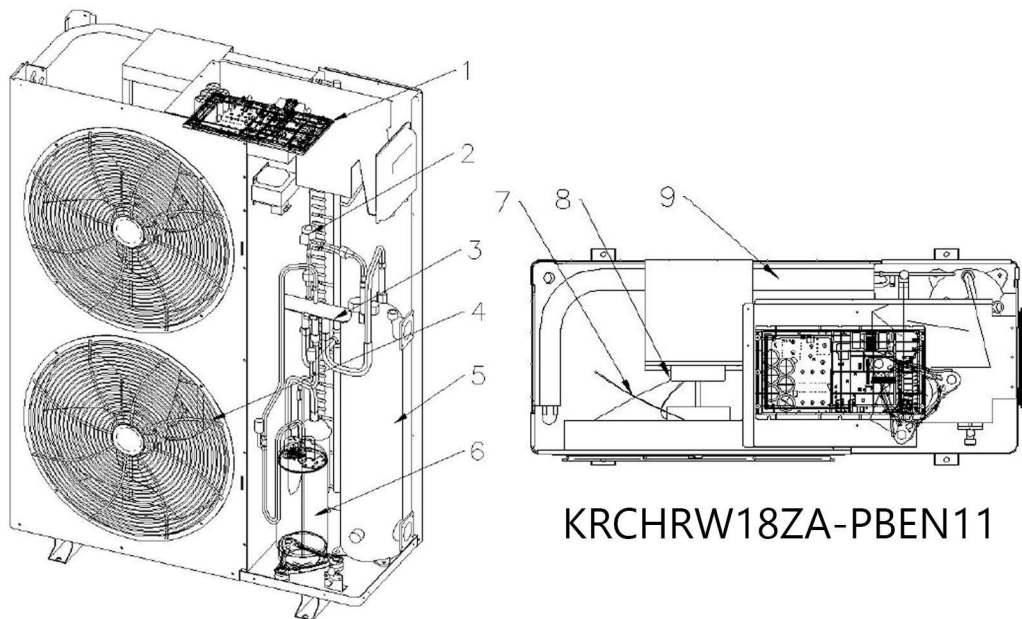

1. Electric Control Box
2. Fan Blade
3. Four-Way Valve
4. Plate Heat Exchanger
5. Main Electronic Expansion Valve
6. Secondary Electronic Expansion Valve
7. EVI DC Inverter Compressor
8. Fan Guard
9. Fan Motor
10. Hydrophilic Aluminum Fin Heat Exchanger

PRODUCT KEY FEATURES

Refrigerant Type: R454b

GWP: 467 Reduced environmental impact compared to conventional refrigerants

High Temperature Water Production

Capable of producing hot water up to 149°F (65°C) for space heating and domestic hot water applications.

Accelerated Heating

Quickly reaches stable operation after startup, delivering higher heating output in shorter time.

Intelligent Defrosting

Rapid defrost recovery maintains heating capacity and minimizes performance loss during low ambient operation.

Automatic Antifreeze Protection (Standby Mode)

Multi-level antifreeze protection automatically activates to prevent freezing and ensure safe operation.

Parameter	Unit	GTCHRW12ZA	GTCHRW18ZA
Power Supply	V/P/Hz	208~230V/1PH/60Hz	208~230V/1PH/60Hz
Heating Condition Ambient Temp. (DB/WB):47/43°F, Water Temp.(in/Out):-/120°F	Heating Capacity Range	BTU/h	21000~61000
	Heating Power Input Range	kW	1.9~5.2
	Heating Capacity	BTU/h	40,900
	Heating Capacity	kW	12.00
Heating Condition Ambient Temp. (DB/WB):17/15°F, Water Temp.(in/Out):-/120°F	Heating Capacity	BTU/h	34,100
	Heating Capacity	kW	10.00
	Heating Power Input	kW	4.26
	COP	/	2.35
Cooling Condition Ambient Temp. (DB/WB):95/-°F, Water Temp.(in/Out):-/44°F	Cooling Capacity Range	BTU/h	15000~47800
	Cooling Power Input Range	kW	1.8~4.8
	Cooling Capacity	BTU/h	34,100
	Cooling Capacity	kW	10.00
Maximum Power Input	kW	5.96	8.94
Maximum Current Input	A	27.08	40.62
Rated Water Flow	gpm(US)	9	14
Water Pressure Drop	ft H2O	14.0532	16.73
Water Connection	NPT	1 inch	1 inch
Refrigerant Type	/	R454B	R454B
Sound Pressure (1m)	dB(A)	45~55	45~58
IP Rating	/	IPX4	IPX4
Protection against Electric Shock	/	I	I
Operating Ambient Temperature	°F	-22~113	-22~113
Heating Outlet Water Temperature	°F	59~149	59~149
Cooling Outlet Water Temperature	°F	41~77	41~77

Remarks:

The above data is based on a 230V power supply and is provided for reference only. In case of changes due to product improvements, the unit nameplate data shall prevail.

DIMENSION AND WEIGHT

The unit has a compact vertical design for space-efficient installation.

Ensure proper structural support and use suitable lifting equipment during handling and mounting.

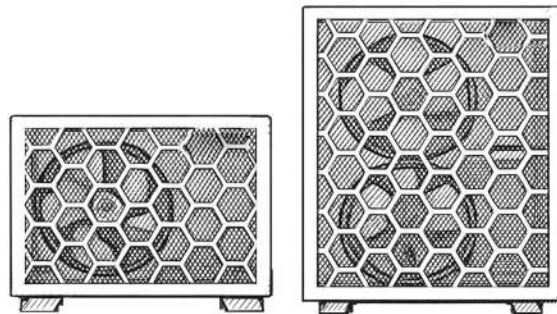

Parameter	Unit	GTCHRW12ZA	GTCHRW18ZA
Weight	lb	262	287
Unit dimensions (L/W/H)	inch	46.0/18.1/33.5	47.6/18.1/53.3

INSTALLATION SPACE REQUIREMENTS

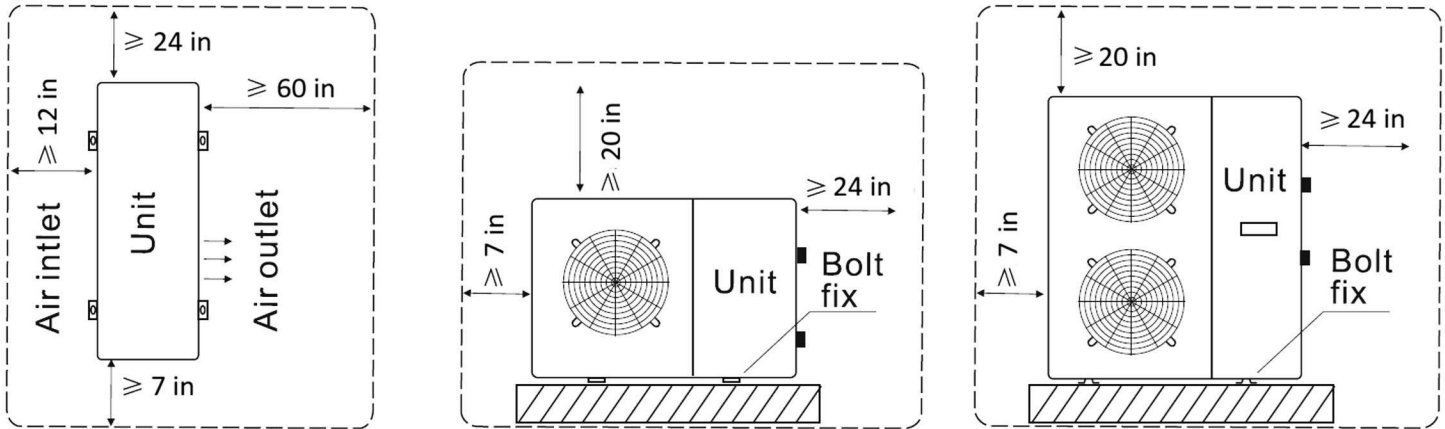

SMART CONTROL

A user-friendly color touch controller with remote APP integration for convenient system monitoring and control.

1. Remote control via smart APP
2. Heating, Cooling, and Hot Water modes
3. Temperature adjustment and scheduling
4. Timer and unit status monitoring
5. RS485 communication interface for BMS integration

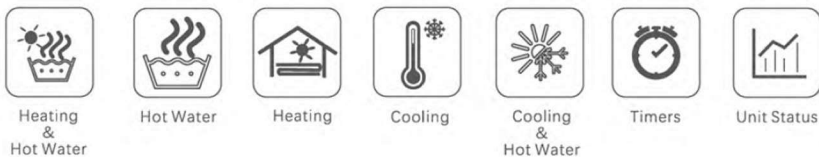

ELECTRICAL REQUIRMENTS

Use a dedicated, properly rated power supply with correct copper wiring and reliable grounding.

Parameter	Unit	GTCHRW12ZA	GTCHRW18ZA
Maximum power input	kW	5.96	8.94
Maximum current input	A	27.08	40.62

ASTRA hydraulic integrated indoor units (150L, 200L, and 300L) provide ideal solutions for a wide range of construction projects, efficiently delivering heating, cooling, and domestic hot water (DHW) to meet diverse building demands.

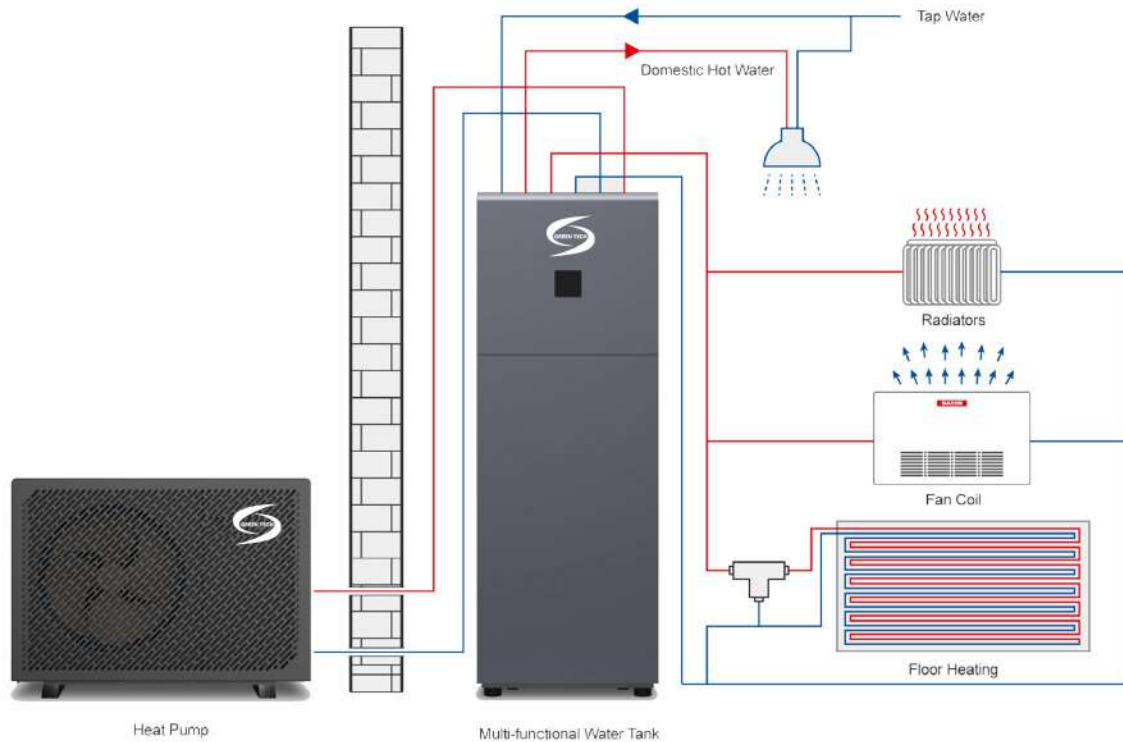

NOTE: Installation shall comply with local codes including CSA B52 and electrical authority requirements



GREEN TECHNOLOGY INTERNATIONAL
www.Greentechastra.com
info@greentechastra.com



HOMY BUILDING SOLUTIONS INC.
 Suite A4, 9131 Keele St, Vaughan
 ON, Canada – L4K 0G7
 Tel: (905) 851 8787
info@homybuild.ca